

GENERAL DESCRIPTION

The No. 99610-A Series Temperature Sensor is an adjustable, temperature-sensing valve which vents pressure when the measured variable exceeds the setpoint.

SPECIFICATIONS

Construction:

Valve Body Cast brass.
Springs Stainless steel.
O-Rings Fluorocarbon.
Power-Pill® Copper, brass, rubber, wax, stainless steel and Teflon*.

Control Pressure: 138 to 276 kPa (20 to 40 psig) through a .8 mm (.032") diameter orifice.

Maximum Control Pressure: 276 kPa (40 psig).

Range: 43 to 107° C. (110 to 225° F.)

Maximum Temperature: 121° C. (250° F.)

Maximum Sensing Element Pressures:

-29 to 66° C. (-20 to 150° F.) -
 2758 kPa (400 psig) non-shock.
 93° C. (200° F.) - 2655 kPa (385 psig) non-shock.
 121° C. (250° F.) - 2516 kPa (365 psig) non-shock.

CAUTION: Do not exceed maximum temperature/pressure ratings.

Setpoint: Adjustable (see Adjustments).

Reset Differential: Non-adjustable
 8° C. (15° F.) maximum without thermowell
 10° C. (18° F.) maximum with thermowell.

Repeatability: ± 1.7° C. (±3° F.)

Dimensions: See Figure 1.

Connections: 1/2" - 14 NPT mounting
 1/4" - 18 NPT control and outlet.

Approximate Shipping Weight:7 Kg. (1-1/2 lbs.)

Air Quality:

Control Medium Air, natural gas, nitrogen.

Filtration (Minimum) 25 microns

Moisture (Pressure Dewpoint) .. 8° C. (15° F.) less than ambient temperature.

Oil Content (Natural Base) 5 PPM

Oil Content (Synthetic Base) 0 PPM

Hydrogen Sulfide: 0 PPM

*Registered tradename of E. I. DuPont Company.

ORDERING INFORMATION

Specify:

1. Model No. (See Table 1)
2. Setpoint
3. Accessories (See Table 1)
4. Tagging

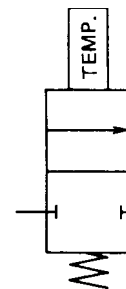
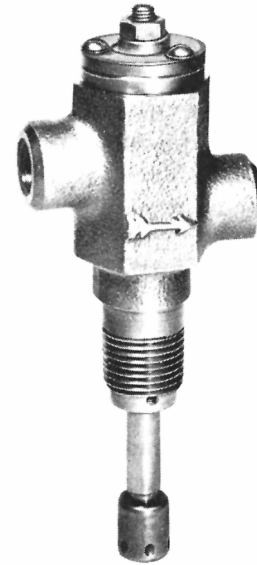

J.I.C. Symbol

Table 1

Model No.	Insertion Depth	Copper Thermowell ¹ (3/4" NPT)	St. St. Thermowell ² (3/4" NPT)
99610-A3	55.6 mm (2-3/16")	81101-A3	81101-A7
99610-A4	68.3 mm (2-11/16")	81101-A4	81101-A8

¹ 1380 kPa (200 psi) max. @ 121° C. (250° F.)

² 3450 kPa (500 psi) max. @ 121° C. (250° F.)

INSTALLATION - See Figure 1

Power-Pill® Location:

Correct location is the most important detail of sensor installation. The Power-Pill® should be installed at a point of true representative temperature in good circulation with maximum insertion depth. If a thermometer is used, its sensing element should be placed adjacent to the Power-Pill®.

Mounting:

The 99160-A Series temperature sensor may be mounted in any position. Vent openings should have fittings installed with openings turned down. Care should be taken to prevent foreign matter from entering the valve ports during installation.

If the sensor is out of doors or in any way exposed to water during cleaning, etc., it should be mounted in a position which will prevent water entry into the valve body. Water trapped in the body will impair operation and could freeze during winter months. The 1/4" - 18 NPT connection can be used for piped vent operation if gas is used.

To mount sensor, screw into pipe or vessel using the 1/2" - 14 NPT male thread at the base of the body.

Connections:

CAUTION: Note arrow on valve body side for correct direction of flow.

The piped vent from the sensor cannot be used as a supply source for any other equipment. If sensor

vent is restricted in this manner, faulty operation will result.

The sensor has two 1/4" - 18 NPT connections used for control pressure and piped vent operation. Control pressure must be provided thru a .8 mm (.032") or smaller diameter orifice.

Thermowell:

The thermowell is used to protect the sensing element from corrosion, high pressure, etc., and to permit removing the sensor from the vessel without draining the system.

When the Power-Pill® is protected by a thermowell, some loss in rate of response is experienced due to the additional metal thickness and insulating effect of the dead air space between the Power-Pill® and thermowell. Improvement in the rate of response can be obtained by partially filling the space between the thermowell and Power-Pill® with a heat conductive material, such as copper or aluminum powder mixed with a binder such as grease, silicone lubricant, or other material compatible with the temperature to which the bulb will be subjected.

To install the Power-Pill® in the thermowell, insert the thermowell in tapped opening and tighten. If a heat conductive medium is used, fill thermowell to a depth great enough to cover the Power-Pill®. Insert the Power-Pill® in the thermowell and tighten the 1/2" - 14 NPT sensor threads into the thermowell.

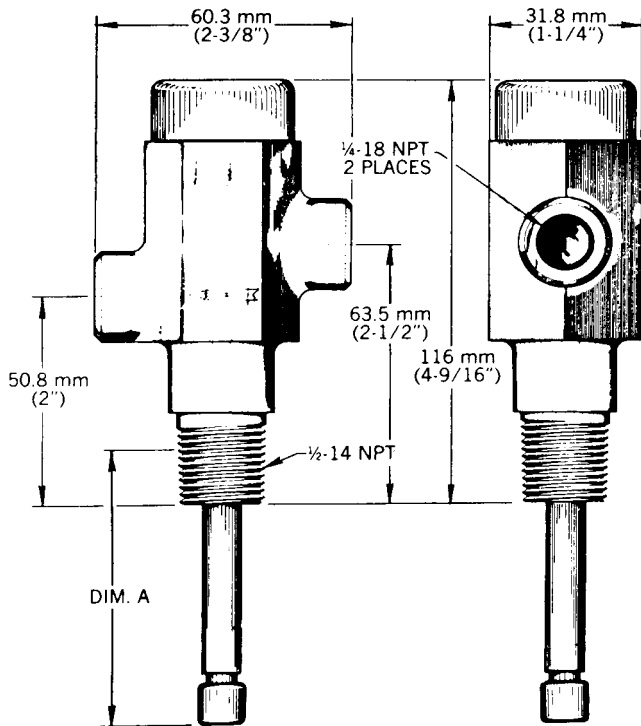

Model No.	Dim. A	Dim. B
99610-A3	55.6 mm (2-3/16")	50.8 mm (2")
99610-A4	68.3 mm (2-11/16")	63.5 mm (2-1/2")

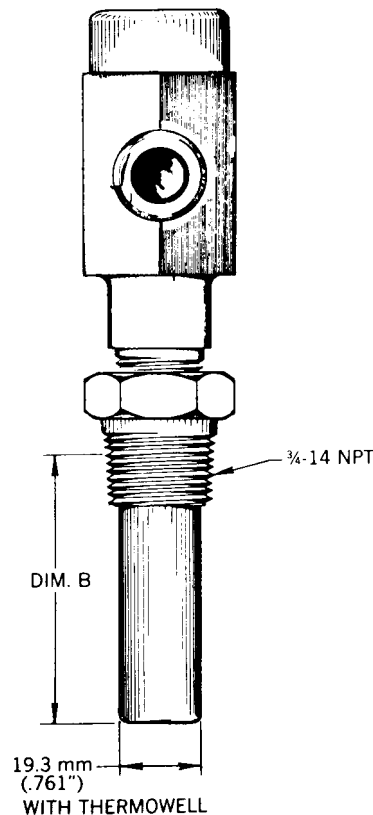

Figure 1

OPERATION - See Figure 2

With an increase in temperature at the Power-Pill®, the stem exerts force on the stem seat. Upon overcoming the load spring force, the stem seat contacts the ball, forcing it off seat and opening the valve. Pressure entering at the control port is vented to atmosphere through the piston and vent port.

ADJUSTMENTS - See Figure 2

Setpoint:

1. Remove protective cap.
2. Loosen lock nut.
3. Loosen the adjusting screw counterclockwise until there is no spring load. This can be checked by turning the adjusting screw IN and OUT with the fingers to determine where the load stops.
4. Allow the sensor to stabilize in a well agitated bath at the desired setpoint.
5. Apply the desired operating control pressure-maximum 276 kPa (40 psi) - at the control port through a .8 mm (.032") diameter or smaller orifice. The control pressure and orifice size must be the same as that used during normal operation.
6. Slowly turn the adjusting screw clockwise until the sensor vents at the specified setpoint $\pm 2.8^{\circ}$ C. ($\pm 5^{\circ}$ F.).
7. Tighten lock nut.
8. Check setpoint by varying measured temperature and trim as necessary.
9. Replace protective cap.

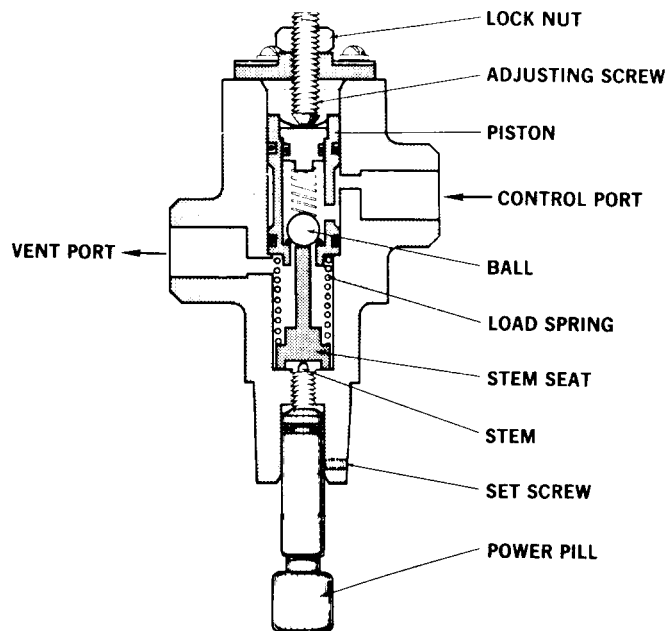

Figure 2

MAINTENANCE - See Figure 3

WARNING: DISASSEMBLE CAREFULLY- SPRING FORCES PRESENT.

CAUTION: Do not subject O-rings to cleaning fluid, acetone, or any halogenated hydrocarbons such as degrease liquids, etc. Clean only with a soft, dry cloth. Metal parts can be cleaned with a suitable solvent then dried thoroughly before reassembly.

O-Rings:

Remove protective cap, cap screws, cap, and piston and spring set assembly (details 3 and 14). Stem and spring (detail 8) can also be removed.

Remove retaining ring from piston. Using a piece of wood, plastic, or other nonmarring material, push against the ball and force the spring seat from the piston. Remove the spring (detail 5) and ball from piston. Remove O-rings from piston and spring seat.

CAUTION: Do not allow any lubricant on ball or its O-ring seat.

Lubricate replacement O-rings (other than O-ring for ball seat) with a non-drying, silicone-type lubricant and place in proper position. Reassemble and recalibrate setpoint.

Power-Pill®:

1. Loosen set screw at base of valve body.
2. Unscrew existing Power-Pill unit and remove from body.
3. Apply operating control pressure - maximum 276 kPa (40 psi) - at the control port through a .8 mm (.032") diameter or smaller orifice. The control pressure and orifice size must be the same as that used during normal operation.
4. If sensor is venting, turn adjusting screw counterclockwise until sensor stops venting. If sensor is not venting, turn adjusting screw clockwise to cause vent then turn counterclockwise until sensor stops venting.
5. Protect O-ring on replacement Power-Pill from being cut as it passes across the set screw hole by using a .025 to .051 mm (.001 to .002") thick by 6.35 mm (1/4") wide shim to cover the hole. Carefully insert the Power-Pill unit until O-ring is past set screw hole. Remove shim. Slowly screw Power-Pill into valve body until sensor vents.
6. Lock Power-Pill in place with set screw.
7. Turn the adjusting screw counterclockwise until sensor stops venting.
8. Recalibrate setpoint as described under Adjustments.

PARTS LIST

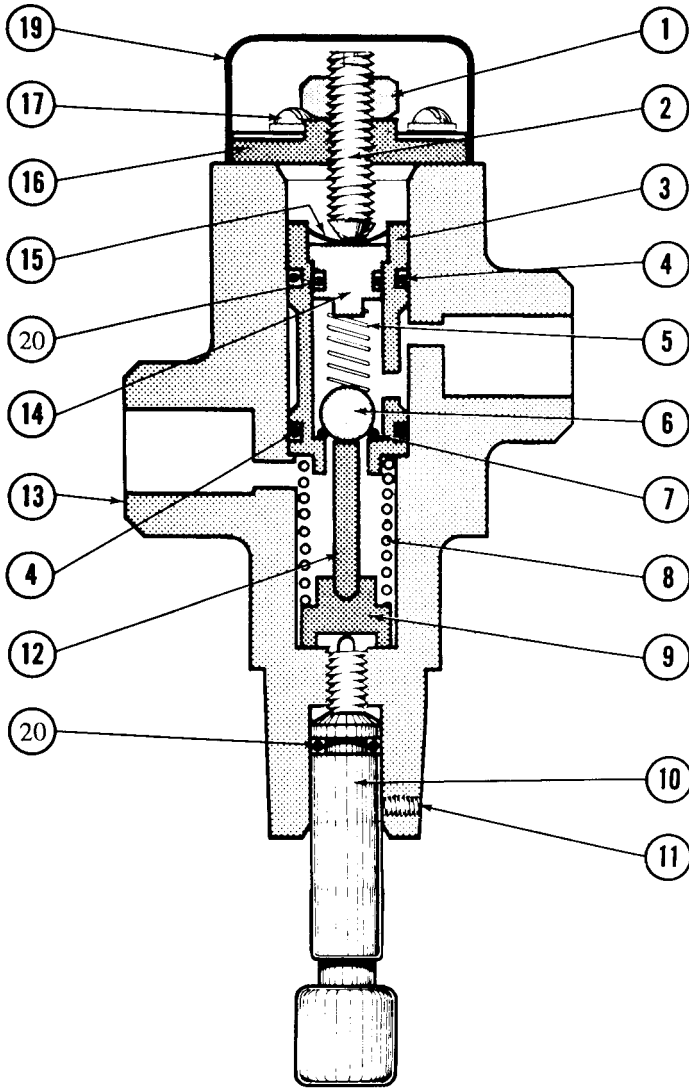

Figure 3

Det. No.	No. Re 'd	Description	Part No.
1	1	Nut	36602-A1800
2	1	Adjusting Screw	36718-E2109
3	1	Piston	26424-A1
*4	2	O-Ring	36240-V0014
5	1	Spring	21586
6	1	Ball	26425-A1
*7	1	O-Ring	36240-S0010
8	1	Spring	26423-A1
9	1	Stem Seat	26420-A1
10	1	Thermo Assembly	See Tab.
11	1	Set Screw	36711-J0309
12	1	Stem	36606-A6
13	1	Valve Body	26419-A1
14	1	Spring Seat	26426-A1
*15	1	Retaining Ring	36605-C1
16	1	Cap	26428-A1
17	3	Cap Screw	33711-H1109
18	1	Thermowell (not shown)	See Tab.
19	1	Protective Cap	20516-H14
20	2	O-Ring	36240-V0010

Tabulation

Model No.	Detail No. 10	Detail No. 18
99610-A3	99611-A3	See Table 1
99610-A4	99611-A4	

*Recommended Spare Parts

Robertshaw

U.S.A. and CANADA

Robertshaw Industrial Products Division

1602 Mustang Drive

Maryville, TN 37801

Phone: (865) 981-3100 Fax: (865) 981-3168

<http://www.robertshawindustrial.com>

Exports

Invensys Appliance Controls

2809 Emerywood Parkway

P.O. Box 26544

Richmond, Virginia 23261-6544

Phone: (804) 756-6500 Fax: (804) 756-6561